



SAVE THESE INSTRUCTIONS - READ ALL INSTRUCTIONS CAREFULLY

⚠ WARNING

READ AND FOLLOW ALL SAFETY INSTRUCTIONS

- Do not let the power cords touch hot surfaces.
- Do not mount in hazardous locations or near gas or electric heaters.
- The use of auxiliary equipment is not recommended by the manufacturer as it may cause unsafe conditions.
- Do not use this equipment for anything but its intended use.
- All electrical connections must be made in accordance with National and Regional electrical codes and performed by a licenced electrician.
- Do not use outdoors.

MODEL	EX220WH-A13-GU	EX220WH-A13BB-GU EC220WH-A13BB-GU-4	CIRCUITRY
120V AC 50/60 Hz	Input wattage: 2W	Input wattage: 3W	<ul style="list-style-type: none"> • Emergency Duration: \geq 2 hours • Recharge Time: 20 Hours • Output Wattage: EX220 : 1W EC220 : 1W + 3W*2PC • Light Source: Ultra Bright LED • Color Temperature: 6500K - 7500K • Ni-cd Battery: EX220 : 3.6V 1300mAh SC EC220 : 3.6V 1300mAh SC
	Input current: 0.01 A	Input current: 0.24 A	
	Efficiency: 0.96 P	Efficiency: 0.98 P	
347V AC 50/60 Hz	Input wattage: 3W	Input wattage: 4W	
	Input current: 0.01 A	Input current: 0.017 A	
	Efficiency: 0.91 P	Efficiency: 0.92 P	



CAN ICES-005 (B) / NMB-005 (B)

A. Canopy Assembly

Insert canopy into housing at a 20 degree angle and twist. Quick snap is now locked firmly.

CAUTION: Trying to remove the canopy while it is locked into place may cause damage.

FIG. A:1

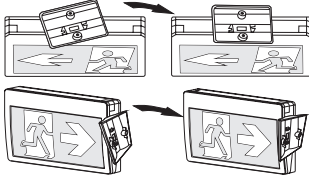
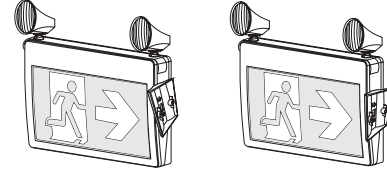

FIG. A:2



B. Assembly Lamp Heads

1. Open front cover with flat head screwdriver.
2. Insert the lamp heads at the corners of the main frame. Select direction of lamp head before inserting.
3. Connect male connector on lamp head to female connector on PCBA.

FIG. B:1

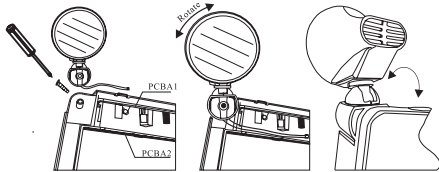
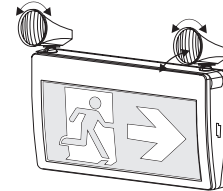

FIG. B:2



INSTALLATION INSTRUCTIONS FOR EX220/ EG220



SAVE THESE INSTRUCTIONS - READ ALL INSTRUCTIONS CAREFULLY

C. Mounting Instruction

THE FIXTURE IS SUITABLE FOR WALL MOUNTING, SIDE MOUNTING AND CEILING MOUNTING

1. Open the front cover by flat screwdriver.(Fig.C-1).
2. Assemble the remote head if needed.
3. Knockout the appropriate mounting hole cover on the black plate.
4. Attach the crossbar to the junction box, set the longer blade of the crossbar touching the J-box
5. Route the proper wire through mounting hole out of the housing. Make the electrical connections inside J-box as the wiring diagram states. (Fig.C-3). Push the excess wire into J-Box, Mount the back plate on the wall. Attach battery connector to PCB, restore the front cover on the unit.

If the pictogram direction assembled is not suitable, you can change the direction of the pictogram or replace it into the diffuser easily. (Fig. C-2)

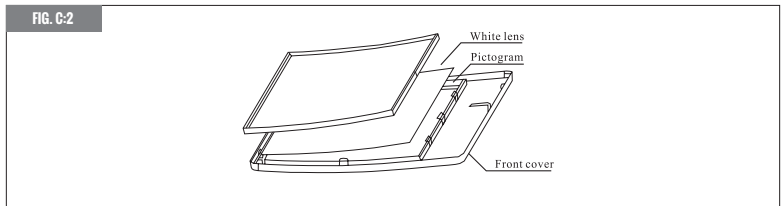
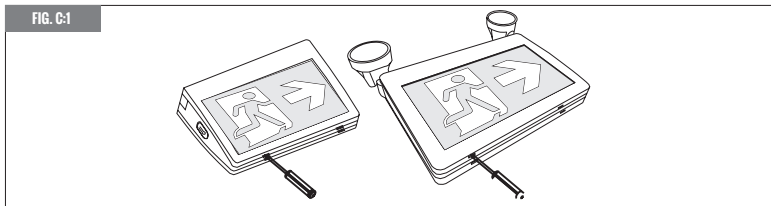

WIRING DIAGRAM

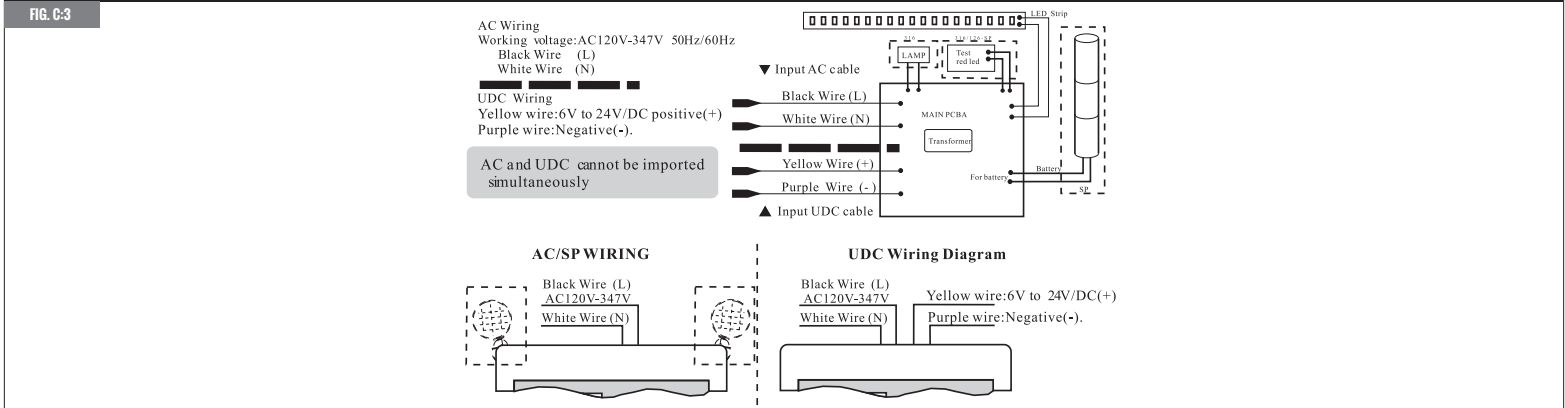

For the ceiling and side mounting purpose, knockout the mounting hole cover on side of top of unit, and assemble the canopy.

1. Attach the crossbar to the junction box, set the longer blade of the crossbar touching the J-box.
2. Route the proper wires through the mounting hole out of the housing.
3. Make the electrical connections inside the J-box as the wiring diagram states.(Fig. C-4)
4. Push the excess wire into the J-box, use the screws to tighten the canopy to the crossbar so that the canopy is securely fastened and tight against the wall.

